



THE 1980 LINCOLN GRAND VERSAILLES

There is only one Lincoln Grand Versailles

Never before, in its history as one of America's most prestigious luxury cars, has Lincoln offered so fine, so meticulous, so handsomely equipped an automobile as the new Grand Versailles.

Grand Versailles is the most exclusive, best equipped Versailles. It has the classic styling and spirit which have made Lincoln a legend. It is built with the distinctive custom touches exceeding one's expectations. So, it is only logical that your finely tuned instincts should tell you that Grand Versailles is your kind of automobile.

Grand Versailles is equipped with an impressive array of style, comfort and convenience features for you and your guests. The more important ones are listed over the next few pages. Such niceties include ultra-soft leathers throughout, extra illumination and pleasant chimes which discreetly remind you to buckle up, switch off lights or remove the key from the ignition.





1980 Lincoln Grand Versailles in Dark Cordovan and Bittersweet pinstripes with aluminum dish wheels



- Complete digital instrumentation: speedometer, tachometer, fuel gauge, voltmeter, oil pressure gauge, water temperature gauge and trip computer
 - Digital day/date elapsed time clock
 - Electronic AM / FM stereo search radio with Dolby cassette and digital display
- Auto-dimming rearview mirror with digital compass and outside temperature display
- Real American walnut wood veneer dash panels



- Twin Comfort Lounge Seat interior with covered center storage bin, cup holder and tray
- Illuminated entry system lights dome and courtesy lamps for convenience and safety

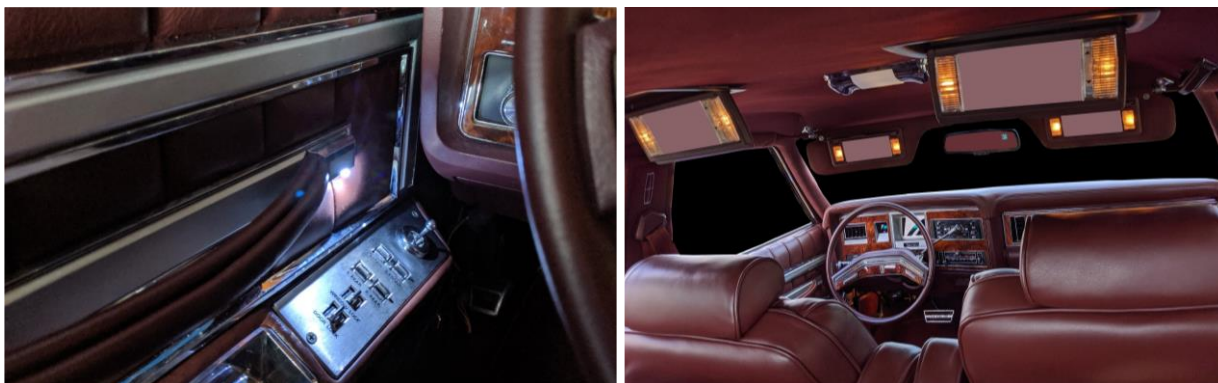

- Ambient lights make switch panels easy to see and adds a soft, pleasing glow to the interior
- With illuminated vanity mirrors, front and rear, you can make final touchups before exiting your Grand Versailles

The very essence of personal luxury

Leather

- Full leather on all seating surfaces
- Leather assist straps on doors, front seat backs and headliner
- Leather map pockets
- Leather door panels
- Leather door armrests, dash pad and steering wheel cover
- Front/rear leather consoles with storage bins and cup holders

Trim

- Real American walnut crotch-cut veneer on dash panels
- Stainless steel door trim
- Opulent matching cut-pile carpeting on floors, kick panels, lower door panels, lower seat backs and floor mats with Versailles script
- Color-keyed cloth covered headliner, pillars and rear French window
- Carpeted luggage compartment and upper inside decklid

Features

- Luxury sound insulation
- Semi-automatic air conditioning with 4-speed fan control
- Tinted glass
- Electronic AM/FM search stereo with Dolby cassette player and four-speakers
- Tilt steering wheel
- Fingertip speed control
- 6-way power driver seat
- Dual reclining Twin Comfort Lounge Seats
- Rear seat center armrest
- Rear head restraints
- Power windows, locks, decklid release and antenna
- Rear defroster
- Interval windshield wipers
- Electronic day/date and elapsed time clock
- Ash receivers in all passenger doors

Functional Features

- Automatic parking brake release
- 14-inch white sidewall steel-belted radial ply tires
- Heavy duty battery
- Bright rocker panel moldings
- Dual remote control exterior mirrors

Refined

In appearance and appointments, the Lincoln Grand Versailles quietly projects an image of elegance and individuality. You will notice this distinction upon your first inspection of this fine motor car.

Exterior

Grand Versailles in Dark Cordovan (5R) • Thickly padded half vinyl coach roof and rear decklid • Unique hood tape stripes • Grand Versailles badges • Color-keyed grille, bumper guards and rub strips

Grand Power

Performance enhanced 5.0 liter (302 CID) V-8 with 78% more horsepower, than the standard Versailles, rated at 235 and 317 lb/ft of torque • Power steering • Power 4-wheel disc brakes

Interior Lights

- Illuminated visor vanity mirrors, front and back • Dome lamp • Dual beam map lights
- Rear seat reading lamps
- Lights in glove box, ashtray, engine, luggage compartment, foot wells and overhead • 13 ambient lights

Exterior Lights

- Front cornering lamps • Coach lamps • Illuminated entry
- Halogen headlamps, low and high beams • Wrap-around taillamps



Driver and passengers are coddled with thoughtful touches, such as: reclining Twin Comfort Lounge seats up front, center armrests (front and rear), rear seat headrests, reading lamps, consoles with cup holders and bins (front and rear), and ambient lighting, throughout, that is both practical and emotive. Ambient lamps illuminate door panel switches, floor wells, cup holders and bins.

Quality

- Minimized Noise, Vibration and Harshness** – One of the primary goals in designing Grand Versailles was to create a car with exceptional interior quietness and a superior ride. In order to attain this level of excellence, engineers developed new innovations specifically for this vehicle. Many of these unique features have been incorporated into the car's suspension, steering, drivetrain, sound package and body structure.
- Super Body Finish** – The Versailles is the first domestic vehicle which has a basecoat and clearcoat paint system. This two-part system is applied by using a base color coat on the vehicle which is re-coated, while wet, with a clear acrylic finish.

Quality Control

- Vehicle Electrical Test System** – This system is designed to improve the electrical reliability of Versailles, thereby reducing the possibility of electrical problems. It is a computerized online inspection test that replaces visual checks on over 50 electrical functions.
- Burke-Port Road Simulator** – Each Versailles is driven under its own power on this simulator. Any unnecessary squeaks or rattles are isolated by either the driver or an individual standing beside the car and are remedied before the unit is allowed to pass.
- Prestige Assurance Program** – This pre-delivery inspection program has been initiated exclusively for Versailles. It helps assure that each vehicle meets the highest standards of quality and workmanship before it leaves the factory.



Versailles' engine is hand-matched to its transmission.



A double coupling joins balanced driveshaft to differential.

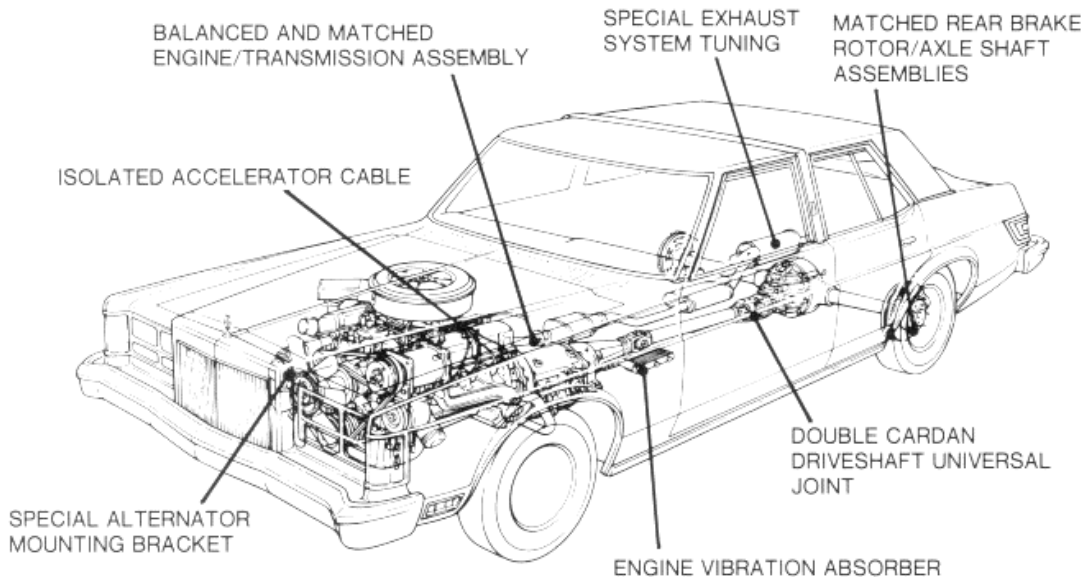

Specifications

Wheelbase	109.9"
Overall Length	201.0"
Overall Width	74.5"
Wheel Tread – Front	54.1"
– Rear	59.0"
Luggage Capacity (cu. ft.)	57.7"
Fuel Capacity (gals.)	14.6
Curb Weight (lb.) 5.0L (302 CID)	19.2
FRONT	
Head Room	3,848
Leg Room	38.0"
Shoulder Room	40.6"
Hip Room	55.6"
REAR	
Head Room	53.4"
Leg Room	37.3"
Shoulder Room	53.6"
Hip Room	55.6"
	51.2"

LINCOLN GRAND VERSAILLES

LINCOLN-MERCURY DIVISION

